

**IP-Router 001001**

## Application program usage

Product family: System devices  
 Product type: IP-Router  
 Manufacturer: Siemens

Name: IP Router N146  
 Order-No.: 5WG1 146-1AB01

## Functional description

The IP Router N146 is a DIN rail mounted device.

The device connects EIB lines via data networks using the Internet Protocol (IP). Also this device offers communication of EIB devices with PC's or other data processing equipment.

The physical connection to the EIB is established via a bus connector terminal block. For connection to the data network (IP via 10BaseT) the device contains an RJ45 socket.

To operate the IP Router requires AC/DC 24 V, which is provided via a second terminal block. The IP Router is powered via this operating voltage terminal connector. This allows the IP Router to send a bus voltage failure notification onto the data network.

The IP Router implements the EIBnet/IP standard for routing of EIB telegrams between lines and for concurrent access to the bus line from any PC.

By using a LAN modem an EIB installation can be remotely accessed even if there is no direct data network connection between a PC and an IP Router. LAN modems are available on the market for standard telephone, ISDN or DSL connections.

The IP Router has these characteristics:

- Simple connection to hierarchically superimposed systems via Internet Protocol (IP)
- Direct access to the EIB installation from any access point to the IP network (EIBnet/IP Tunneling)
- Fast communication between EIB lines, EIB areas and systems (EIBnet/IP Routing)
- Communication between buildings and facilities
- Filtering and routing of telegrams depending on
  - individual address
  - group address
- LED display of
  - operation
  - EIB communication
  - IP communication
- Simple configuration with standard ETS
- Easy connection to SCADA and Facility Management systems (see: Supported Software)

Using the existing data network for communication between bus lines in non-residential buildings is a logical step. The advantages are: fast communication between EIB lines, extension of an EIB system beyond one building by using LAN and WAN connections, direct transmission of EIB data to any network user, EIB remote configuration from any network access point.

The IP Router N146 logically connects EIB bus lines by transmitting EIB telegrams between them via a data network but separates them galvanically. This allows to run each bus line independently from other bus lines.

The N146 can be used as line coupler or area coupler in existing *EIB* networks as well as in new *KNX EIB* networks. The N146 holds a filter table determining, which bus telegrams are transmitted or blocked from or to the bus line thus reducing the bus load. The filter table is automatically generated by the ETS (*EIB Tool Software*) during configuration and start-up of the system.

The physical address of the IP Router assigned by ETS automatically determines the IP Router function as a line coupler or area coupler. The definition follows these assignments:

Coupler function	Line
Area coupler	Main line 1- 15
Line coupler	Line 1- 15

**IP-Router 001001**

**Note**

When assigning the physical address take care that IP Router and line couplers receive the topologically correct physical address (Fig. 1, IP Router as area coupler and line coupler).

Adhere to these rules:

**Rule 1:**

In general an IP Router N 146 is used as a line coupler or an area coupler. The physical address has the format x.y.0, with x=1...15, y=1...15.

**Rule 2:**

If an IP Router N 146 is applied as an area coupler with the physical address x.0.0 then no other IP Router with the line coupler address x.y.0 (y=1...15) shall be placed topologically „below“ this IP Router (Fig. 2, IP Router N 146 as area coupler).

**Rule 3:**

If an IP Router N146 is applied as a line coupler (e.g. with physical address 1.2.0) then no other IP Router N146 shall be used with a superior area coupler address (e.g. 1.0.0) in this installation (Fig. 3, IP Router N 146 as line coupler).

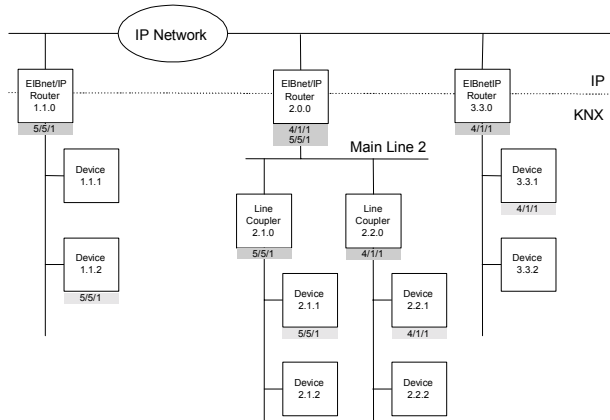

Figure 1. IP Router N 146 as area and line coupler

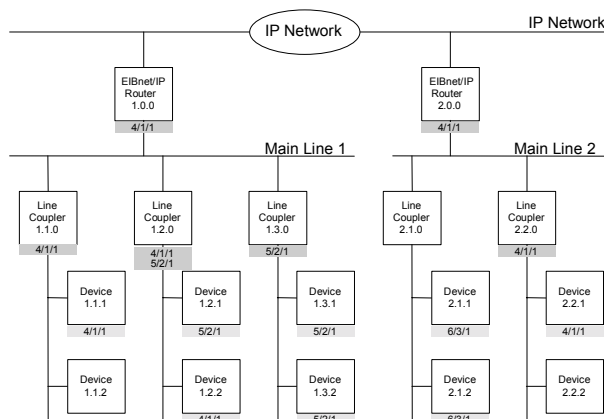

Figure 2. IP Router N 146 as area coupler

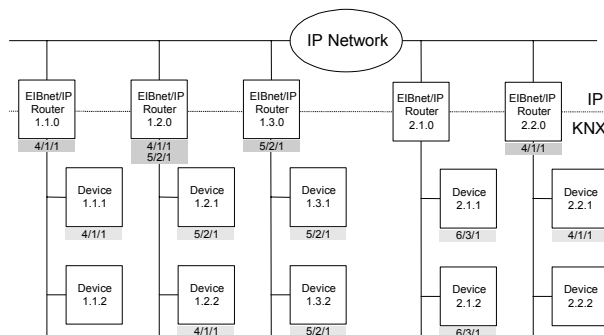

Figure 3. IP Router N 146 as line coupler

**IP Router as interface to the bus (EIBnet/IP Tunneling)**

A direct connection between a networked PC and the bus can be established via a data network and the IP Router N 146. This allows for accessing the bus from any access point in the data network.

**IP address assignment**

The IP address of the IP Router N146 is assigned manually using ETS or automatically by a DHCP server in the IP network. Assignment of the IP address by a DHCP server allows for changes of the device IP address without using ETS. Configuration of the DHCP server may require the MAC address, which is printed on the device.

Please consult your network administrator regarding configuration of the parameters device IP address, subnet mask, and DHCP.

**Default factory settings**

By default the EIBnet/IP Routing function is active. When two EIBnet/IP routers are connected with each other via

**IP-Router 001001**

a cross-over cable or via a network hub, bus telegrams are routed by the EIBnet/IP Router without any configuration.

The IP Router ships with these default factory settings:

- Physical address of the IP Router: 15.15.0 (= FF00 hex)
- Filter group telegrams
- All bus telegrams are repeated in case of transmission errors
- The IP Router acknowledges routed telegrams only
- Support for devices with mis-matching physical address
- Route broadcast telegrams
- Monitor the bus line

Behavior on bus voltage loss / recovery on the bus line

When the IP Router detects a loss of bus voltage on the bus line, this error is saved and announced via EIBnet/IP. When the IP Router detects recovery of bus voltage on the bus line, the error flag is deleted and the resumption of bus voltage is announced via EIBnet/IP.

Configuration with ETS

The IP Router N 146 can be configured with ETS2 V1.2 and later versions.

**Note**

The IP Router can be reset to the default factory settings by pressing the learning button for more than six seconds when the operation voltage is turned on. The transition to the default state is indicated by a blinking programming LED. All parameter settings are deleted by this reset action.

**Communication objects**

The application program does not contain any communication objects.

**Parameter General**

General	Routing (Bus > IP)	Routing (IP > Bus)	IP Config 1
Support of unconfigured interfaces	enabled		
Monitoring of bus voltage failure	enabled		
Device name (max. 30 char)	IP Router N146		

Parameter	Settings
<b>Support of unconfigured interfaces</b>	disabled <b>enabled</b>
By enabling this parameter RS232 interfaces with a topologically incorrect address can be supported allowing for configuration across several bus lines.	
<b>Monitoring of bus voltage failure</b>	disabled <b>enabled</b>
Bus voltage failure and bus voltage recovery can be announced via EIBnet/IP.	
<b>Device name (max. 30 char)</b>	Name with max. 30 characters
This parameter determines the name (max. 30 characters) of the IP Router N146, which is used for easy recognition of the device when searched by an EIBnet/IP visualisation or the ETS.	

**IP-Router 001001**

**Parameter Routing Bus → EIBnet/IP**

General	<b>Routing (Bus &gt; IP)</b>	Routing (IP > Bus)	IP Config 1
Group telegrams of main groups 0 to 13		filter (normal)	
Group telegrams of main group 14 and 15		transmit all	
Individually addressed and broadcast telegrams		filter (normal)	
Telegram confirmation of group oriented telegrams		only if routed	

Parameter	Settings
<b>Group telegrams of main groups 0 to 13</b>	transmit all block <b>filter (normal)</b>
This parameter defines the filter function for group telegrams of main groups 0 to 13 received from the bus. If the default „filter (normal)“ setting is selected the respective filter table entry is checked to determine whether the group telegram should be forwarded to the IP network.	
<b>Group telegrams of main groups 14 and 15</b>	<b>transmit all</b> block
This parameter defines the filter function for group telegrams of main groups 14 and 15 received from the bus. If the default „transmit all“ setting is selected all group telegrams of main groups 14 and 15 are forwarded to the IP network. Otherwise all group telegrams of main groups 14 and 15 are blocked.	
<b>Individually addressed and broadcast telegrams</b>	transmit all block <b>filter (normal)</b>
This parameter defines the filter function for individually addressed and broadcast telegrams. If the default „filter (normal)“ setting is selected the telegrams are filtered based on the individual address of the IP Router. Broadcast telegrams are always forwarded unless this parameter is set to “block”. Independent of this parameter broadcast telegrams are always accepted by the IP Router itself.	
<b>Telegram confirmation of group oriented telegrams</b>	<b>only if routed</b> always
If this parameter is set to „always“ group telegrams are confirmed even if they are not forwarded onto the IP network.	

**Parameter Routing EIBnet/IP → Bus**

General	Routing (Bus > IP)	<b>Routing (IP &gt; Bus)</b>	IP Config 1
Group telegrams of main groups 0 to 13		filter (normal)	
Group telegrams of main group 14 and 15		transmit all	
Individually addressed and broadcast telegrams		filter (normal)	

Parameter	Settings
<b>Group telegrams of main groups 0 to 13</b>	transmit all block <b>filter (normal)</b>
This parameter defines the filter function for group telegrams of main groups 0 to 13 received from the IP network. If the default „filter (normal)“ setting is selected the respective filter table entry is checked to determine whether the group telegram should be forwarded to the bus.	
<b>Group telegrams of main groups 14 and 15</b>	<b>transmit all</b> block
This parameter defines the filter function for group telegrams of main groups 14 and 15 received from the IP network. If the default „transmit all“ setting is selected all group telegrams of main groups 14 and 15 are forwarded to the bus. Otherwise all group telegrams of main groups 14 and 15 are blocked.	
<b>Individually addressed and broadcast telegrams</b>	transmit all block <b>filter (normal)</b>
This parameter defines the filter function for individually addressed and broadcast telegrams. If the default „filter (normal)“ setting is selected the telegrams are filtered based on the individual address of the IP Router. Broadcast telegrams are always forwarded unless this parameter is set to “block”. Independent of this parameter broadcast telegrams are always accepted by the IP Router itself.	

## IP-Router 001001

## Parameter IP Configuration

General	Routing (Bus > IP)	Routing (IP > Bus)	IP Config 1
<b>IP Routing Multicast Address</b>			
IP Address Assignment		by DHCP Server	
Byte 1	224		
Byte 2	0		
Byte 3	23		
Byte 4	12		

Parameter	Settings
<b>IP Address Assignment</b>	by DHCP Server manual input
<p>This parameter determines the type of IP address assignment.</p> <p>By default the parameter is set for automatic assignment of the IP address by a DHCP server.</p> <p>If "manual input" is selected two additional tabs appear for manual input of the IP address, subnet mask, and the default gateway address.</p>	
<b>IP Routing Multicast Address</b> <b>Byte 1,</b> <b>Byte 2,</b> <b>Byte 3,</b> <b>Byte 4</b>	224.0.23.12
<p>This parameter determines the IP Routing Multicast Address for EIBnet/IP Routing. EIBnet/IP Routing forwards bus telegrams to all IP Routers that use the same IP Routing Multicast Address.</p> <p>The factory default setting for the IP Routing Multicast Address is <b>224.0.23.12</b>. This is the Multicast Address that IANA assigned to EIBA and reserved for this purpose.</p> <p>Each byte of the four byte IP Routing Multicast Address is set separately, with a value range of 0...255 for each byte.</p>	
<b>IP Address</b> <b>Byte 1,</b> <b>Byte 2,</b> <b>Byte 3,</b> <b>Byte 4</b>	0.0.0.0
<p>This parameter is only visible if manual input was chosen for IP Address Assignment. It determines the IP address of the IP Router.</p> <p>The factory default setting for the IP address is <b>0.0.0.0</b>. This default value must be replaced by a valid IP address.</p> <p>Each byte of the four byte IP Routing Multicast Address is set separately, with a value range of 0...255 for each byte.</p>	

Parameter	Settings
<b>IP Subnet Mask</b> <b>Byte 1,</b> <b>Byte 2,</b> <b>Byte 3,</b> <b>Byte 4</b>	0.0.0.0
<p>This parameter is only visible if manual input was chosen for IP Address Assignment. It determines the IP subnet mask used by the IP Router.</p> <p>The factory default value is <b>0.0.0.0</b>. This default value must be replaced by a valid subnet mask. Valid subnet mask values are e.g. 255.255.255.0 or 255.255.240.0.</p> <p>Each byte of the four byte IP Routing Multicast Address is set separately, with a value range of 0...255 for each byte.</p>	
<b>IP Standard Gateway</b> <b>Byte 1,</b> <b>Byte 2,</b> <b>Byte 3,</b> <b>Byte 4</b>	0.0.0.0
<p>This parameter is only visible if manual input was chosen for IP Address Assignment. It determines the IP address of the IP Standard Gateway.</p> <p>The factory default value is <b>0.0.0.0</b>. This default value may be replaced by a valid IP address.</p> <p>Each byte of the four byte IP Routing Multicast Address is set separately, with a value range of 0...255 for each byte.</p> <p>The Standard Gateway transmits IP datagrams to IP devices with IP addresses outside of the local network. Use the predefined (invalid) IP address (<b>0.0.0.0</b>) if the device shall be configured without a Standard Gateway.</p>	

**IP-Router 001001**

**Supported Software**

Here is a list of software supporting the IP Router N 146.

ComBridge Studio

IPAS GmbH  
Grabenstr 149 a  
47057 Duisburg  
[<http://www.ipas-products.com>]